

Łańcuchy transportowe typ MT z wysoką płytką
Conveyor chains with deep links type MT
DIN 8167

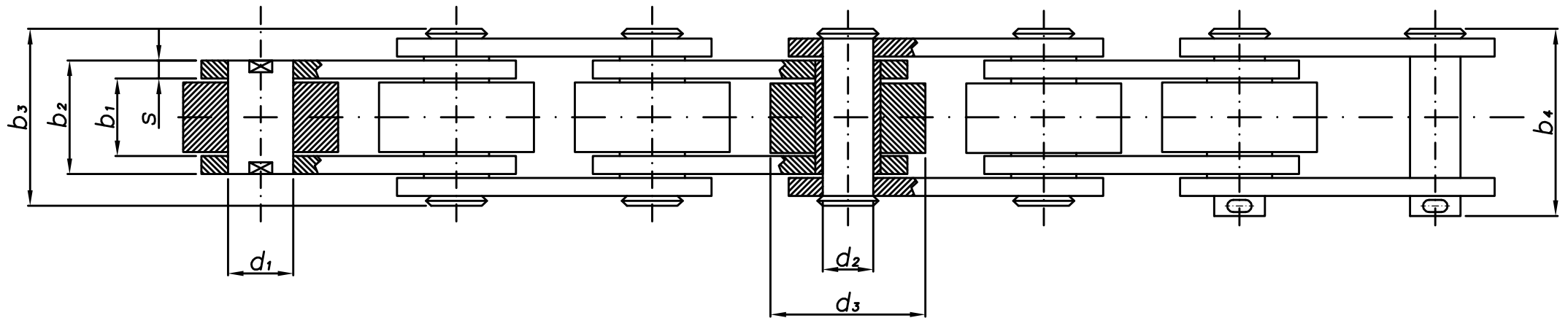
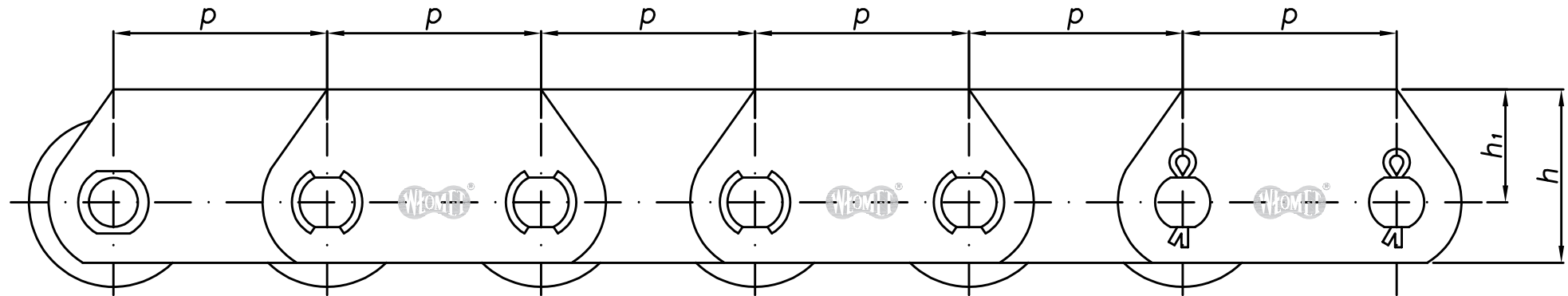

Łańcuchy transportowe typ MT z wysoką płytką

Conveyot chains with deep links type MT

DIN 8167

	p								b ₁ min	b ₂ max	b ₃ max	b ₄	d ₁ max	d ₂ max	d ₃ max	s min	h max	h ₁	F min
	mm								mm	mm	mm	mm	mm	mm	mm	mm	mm	mm	kN
1	2								3	4	5	6	7	8	9	10	11	12	13
M 20	40	50	63	80	100	125	160	16,00	22,00	33,00	37,00	9,00	6,00	25,00	3,00	25,00	16,00	20,00	
M 28	50	63	80	100	125	160	200	18,00	25,00	36,00	40,00	10,00	7,00	30,00	3,00	30,00	20,00	28,00	
M 40	63	80	100	125	160	200	250	20,00	28,00	41,00	45,00	12,50	8,50	36,00	4,00	35,00	22,50	40,00	
M 56	63	80	100	125	160	200	250	24,00	33,00	48,00	54,00	15,00	10,00	42,00	4,00	45,00	30,00	56,00	
M 80	80	100	125	160	200	250	315	28,00	39,00	55,00	64,00	18,00	12,00	50,00	5,00	50,00	32,50	80,00	
M 112	80	100	125	160	200	250	315	32,00	45,00	65,00	73,00	21,00	15,00	60,00	6,00	60,00	40,00	112,00	
M 160	100	125	160	200	250	315	400	37,00	53,00	78,00	85,00	25,00	18,00	70,00	8,00	70,00	45,00	160,00	
M 224	125	160	200	250	315	400	500	43,00	60,00	85,00	97,00	30,00	21,00	85,00	8,00	90,00	60,00	224,00	
M 315	160	200	250	315	400	500	630	48,00	70,00	100,00	114,00	36,00	25,00	100,00	10,00	100,00	65,00	315,00	

F – obciążenie zrywające (min.)

F – breaking load (min.)